

PERMIT

CITY OF NAPOLEON - BUILDING DEPARTMENT
 255 West Riverview Avenue, Napoleon, Ohio 43545 - 419-592-4010

Permit No. 697-77 Issued 4/28/77
date

Job Location 179 E. Maumee Ave.
address

Lot 16 Lowes 1st Add'n.
sub/div or legal discript

Issued By Ronald D. Sommerberg
building official

Owner David Gariepy 592-1991
name tel.

Address 179 E. Maumee Ave.

Agent Self Same
builder-eng.-etc. tel.

Address Same

Description of Use Install Mini-kitchen
units in Motor Inn rooms.

Residential XX
no. dwelling units

Commercial XX Industrial _____

New _____ Add'n. _____ Alter XX Remodel _____

Mixed Occupancy _____

Change of Occupancy _____

Estimated Cost \$ 4,500.00

FEES	BASE	PLUS	TOTAL
<input checked="" type="checkbox"/> BUILDING	\$35.00	\$24.50	\$59.50
<input checked="" type="checkbox"/> ELECTRICAL	\$18.00	\$7.70	\$25.70
<input type="checkbox"/> PLUMBING			
<input type="checkbox"/> MECHANICAL			
<input type="checkbox"/> DEMOLITION			
<input type="checkbox"/> ZONING			
<input type="checkbox"/> SIGN			
WATER TAP			
SEWER TAP			
TEMP. ELECT.			
ADDITIONAL PLAN REVIEW	Struct. --- hrs	Elect. --- hrs	-0-
TOTAL FEES.....			\$ 85.20
LESS MIN. FEES PAID	<u>4.18.77</u> <small>date</small>		\$85.20
BALANCE DUE.....			-0-

ZONING INFORMATION
n/a

district	lot dimensions	area	front yd	side yds	rear yd
max hgt	no pkg spaces	no ldg spaces	max cover	petition or appeal req'd	date appr

WORK INFORMATION:

approx. Dimensions ea. room
 Size: Length 18' Width 15' Stories 1 Ground Floor Area 1394sq' approx.

Height _____ Building Volume (for demo. permit) _____ cu. ft.

Electrical: Install wiring to proposed units. # 200 AMP SERVICE
brief description

Plumbing: _____
brief description

Mechanical: _____
brief description

Sign: _____ Dimensions _____ Sign Area _____
type

Additional Information: Electrical installation shall conform to N.E.C. 1975 edition
and manufacturers installation instructions. See attached letter from Robert
Jones-Chief Enforcement Official, O.A.C.

Date _____ Applicant Signature David Gariepy
owner-agent



City of NAPOLEON, OHIO

255 RIVERVIEW AVENUE — (419) 592-4010

697-77

Mayor

Robert G. Heft

Clerk-Treasurer

Rupert W. Schweinhagen April 26, 1977

Members of Council

Vern Holers, President

James Jackson

William Young

Earl Richardson

Lawrence Haase

David Strobel

City of Napoleon
Building Department
P.O. Box 151
Napoleon, Ohio 43545

SUBJECT: NAPOLEON MOTOR INN
MINI-KITCHEN INSTALLATIONS

Gentlemen:

After review of the sketches submitted for installation of the compact kitchen units for the individual rooms in subject Motor Inn, it is our opinion that the units will not have to be vented. The decision for not venting is based upon the units being electrical and the use being Residential Buildings, Transient as defined under Chapter 4101:2-55 of the Ohio Administrative Code.

Very truly yours,



Robert C. Jones, P.E.
Chief Enforcement Official

RCJ/fbh

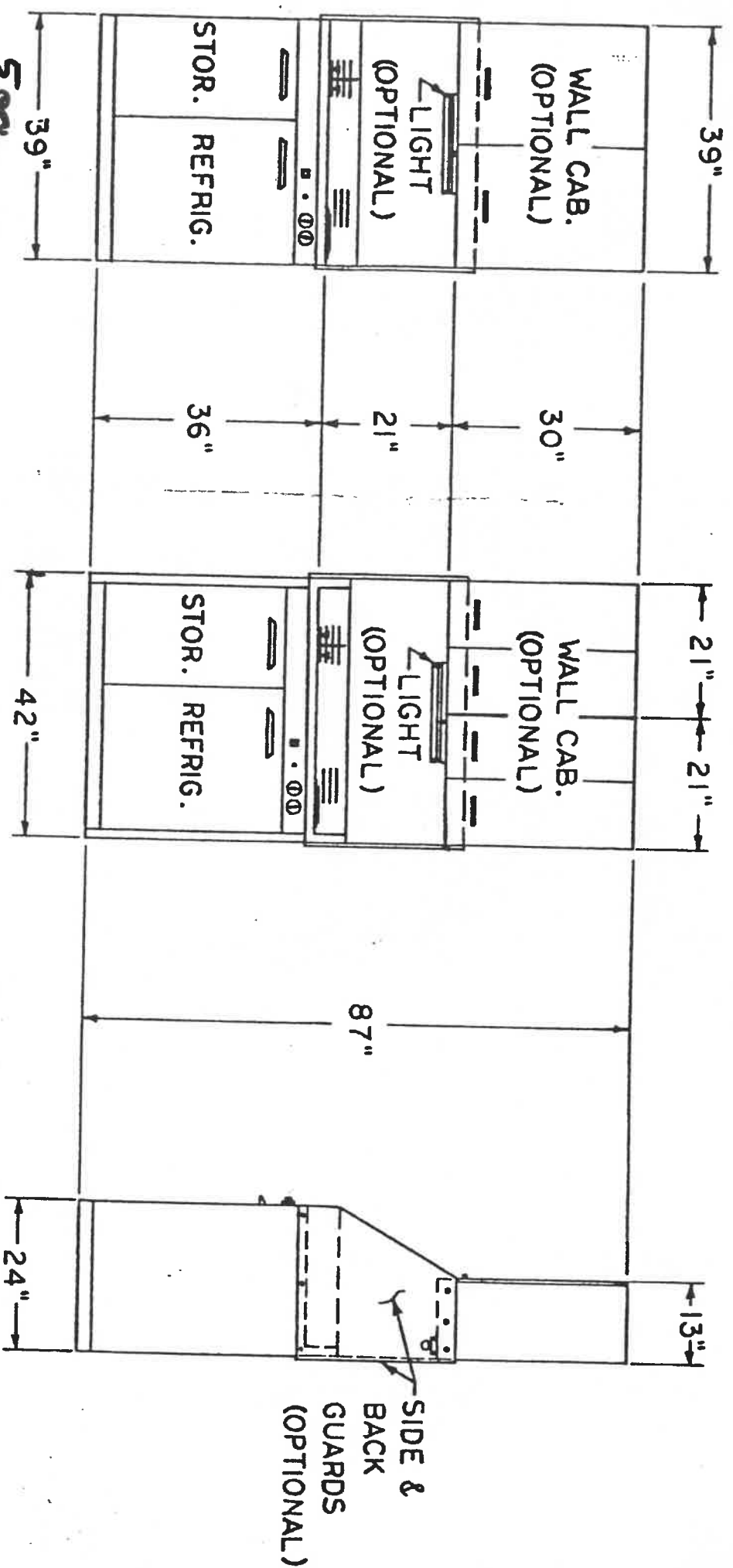
PLAN VIEWS (SEE OTHER SIDE FOR ROUGHING-IN DIMENSIONS)



500

RIGHT HAND  **LEFT HAND** 

K39ES ELECTRIC RANGE COMBINATION

K39GS GAS RANGE COMBINATION

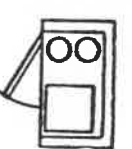
RIGHT HAND  **LEFT HAND** 

KR42E ELECTRIC RANGE COMBINATION

KR42G GAS RANGE COMBINATION

115 V - APPROX. 15 AMP.

King "WORTH ITS WEIGHT IN GOLD."

MINI-KITCHEN

39"-42" SERIES

ROUTING-IN DIMENSIONS
(SEE OTHER SIDE FOR PLAN VIEWS)

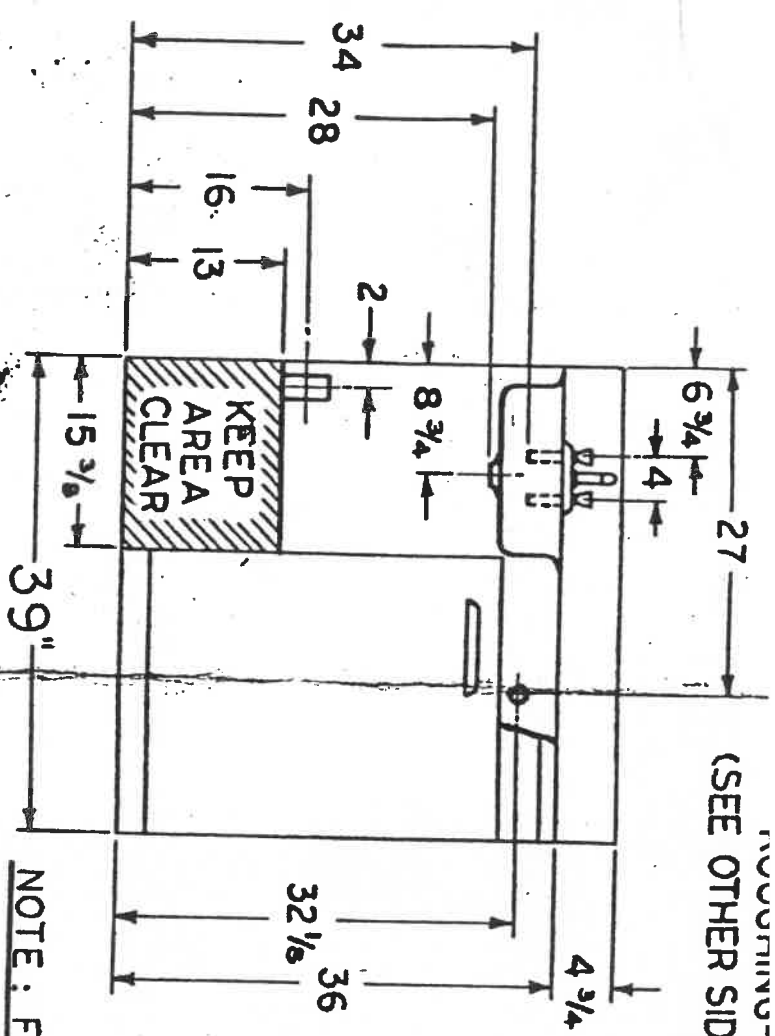

NOTE: FRONT VIEW
RIGHT HAND UNITS SHOWN

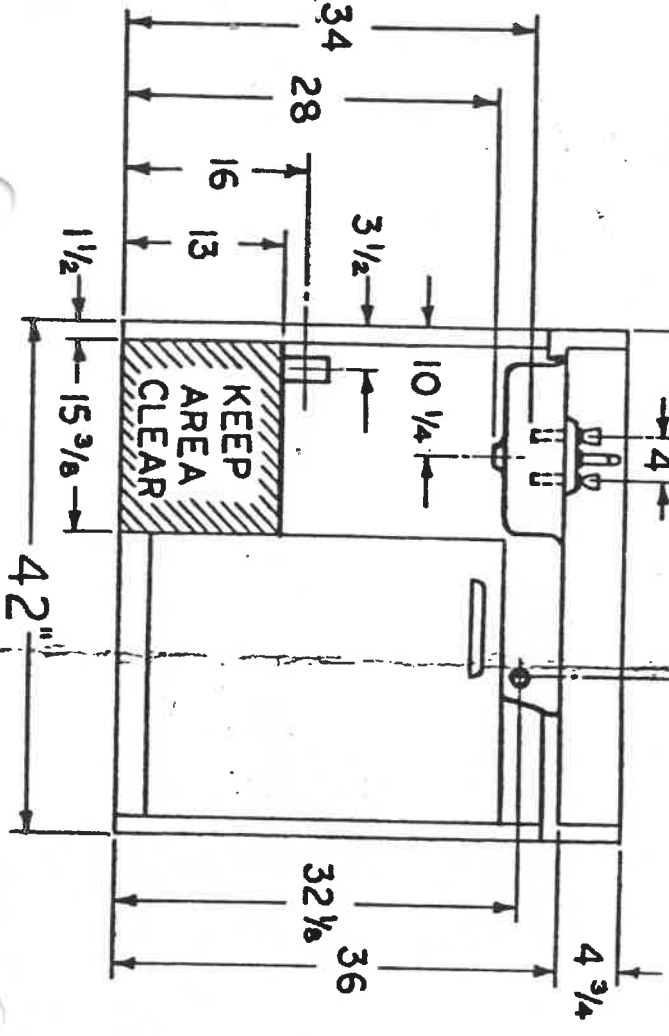
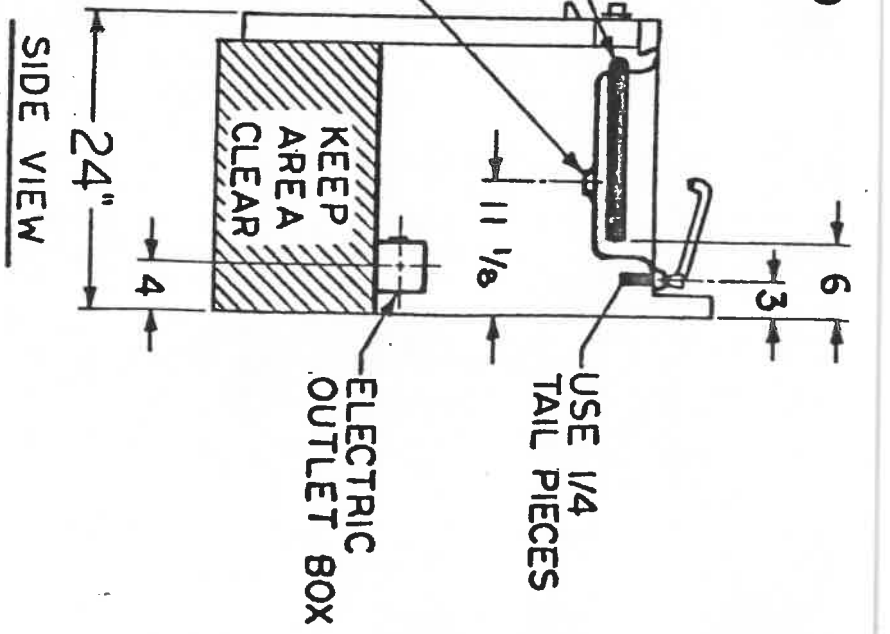

KING REFRIGERATOR CORP
76-02 WOODHAVEN BOULEVARD
GLENDALE, N.Y., 11227

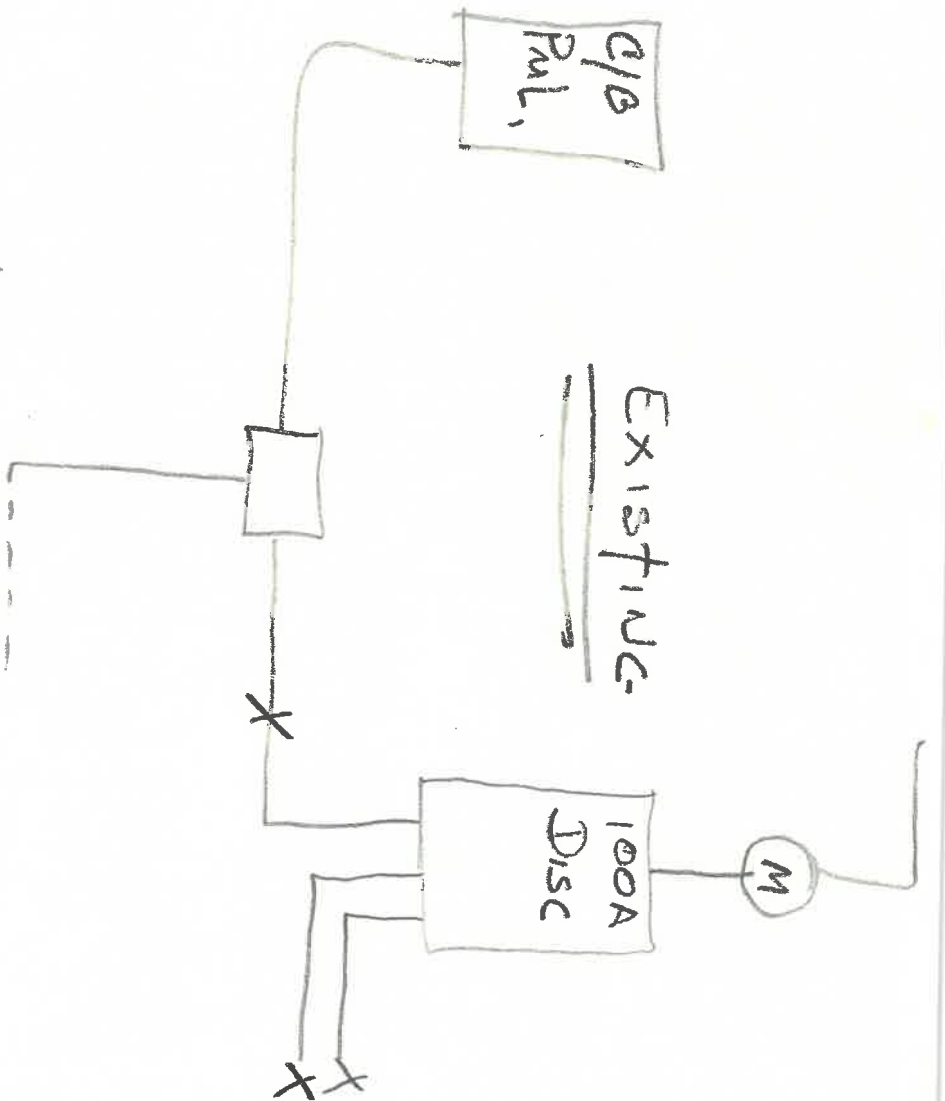
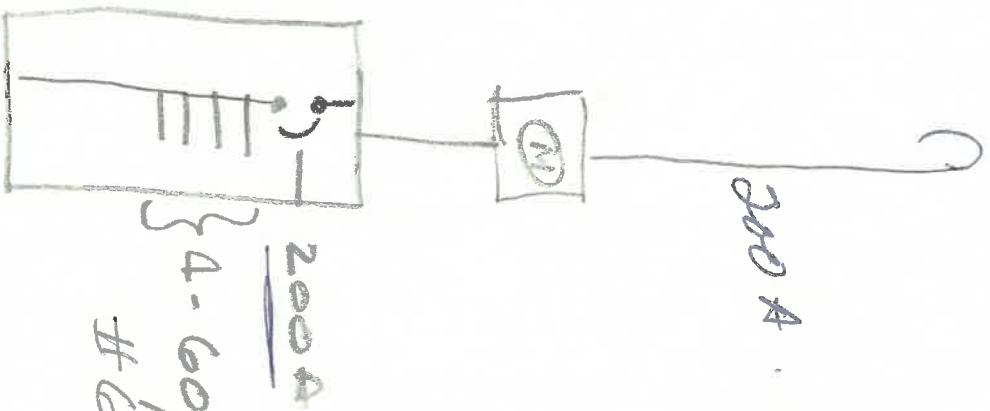

TOTAL OF 13. MOTEL RMS.
 6 WILL HAVE KITCHENS - UNITS -

NAPOLÉON MOTOR INN SAMPLE ROOM

